

The logo for SIDSA, featuring the letters S, I, D, S, and A in a stylized, bold font. The letters are white and set against a dark red background. The letters are arranged in a sequence with diagonal slashes between them, all contained within a white rectangular border.

S / I / D S / A

Experience SID Quality

// Product Catalogue



// SHREDDING // MIXING // PUMPING // SEPARATING // PLANNING // DEVELOPING

MAIN APPLICATION FIELDS



RECYCLING PLANTS



WASTE RECYCLING

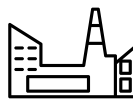

REFUSE DERIVED FUEL (RDF)



CEMENT PLANT



MSW TREATMENT AND DISPOSAL LINE



HAZARDOUS WASTE DISPOSAL CENTER



TYRES TREATMENT AND DISPOSAL LINE



CHEMICAL PLANT



PHARMACEUTICAL PLANT



BIOMASS AND FERMENTATION PLANT



POWER PLANT



MINE SLUDGE AND COKE DISPOSAL



SEWAGE DISPOSAL PLANT



FOOD INDUSTRY



// Table of Content

Company Profile	4
Pre-Shredders	6
Fine Shredders	10
Rotary Shears	14
SMP-Installations	20
Pumps	24
Mixers	26
General Options	28
Customer Service	30
SIDSA Group	32

This brochure is also available online in the following languages

GERMAN



ENGLISH



FRENCH



Company Profile

EXPERIENCE SIDSA QUALITY SINCE 1972

SIDSA with its origins in Switzerland is a company who designs, manufactures and erects a wide range of machinery and installations for waste treatment and process technologies. SIDSA is today the leading company for the planning and construction of complete shredding installations.

Customized solutions by SIDSA are used in many industries, such as: recycling plants, incinerator plants, cement industry, waste to energy and RDF plants, etc.

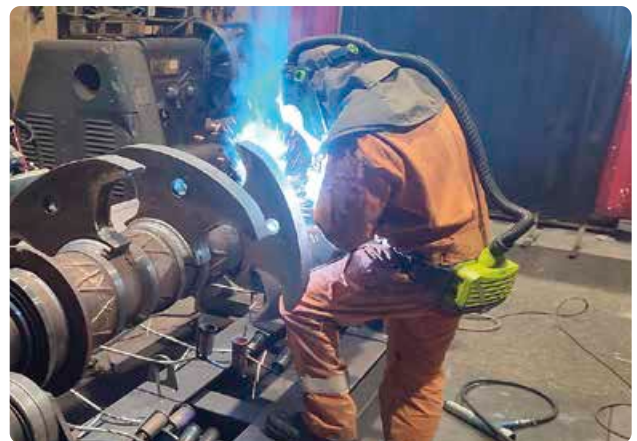

// Our History

- 1972**
SID starts building rotary shredders
- 1982**
SID becomes an independent company
- 1988**
The first machine with automatic ejection of unshreddables is built
- 1989**
The first SMP (Shredding-Mixing-Pumping) test installation is being built
- 1994**
SID Deutschland GmbH is founded in Germany
- 1996**
The world's biggest shredding installation is put into operation in Stuttgart
- 1998**
First Hazardous Waste SMP is erected
- 2003**
SolidPumps company is integrated into SID group
- 2005**
SID installs the first SMP in China



Whether you require design, manufacturing, repair or waste management consultancy services, we are here for you.

Our commitment to excellence, quality and reliability is absolute and we are proud to contribute to the success of your business.

At SIDSA, we are determined to offer you the latest advances in waste treatment technology and pride ourselves on providing robust, customised solutions for all your facilities.

Our experienced team of experts is ready to take on the most demanding challenges to deliver high quality services.

WHY CHOOSE SIDSA:

- + Standardised and customised solutions designed to meet your specific needs.
- + A team of dedicated and competent experts.
- + Innovative and proven technologies to maximise operational efficiency.
- + A commitment to sustainable development and environmental protection.

Contact us today to find out more about our waste treatment services.

- 2006**
SID Machinery (Beijing) Co., Ltd. is founded in China
- 2009**
SID launches 4-shaft shredders
- 2011**
New mobile platforms are developed
- 2013**
SIDSA Environmental Pvt. Ltd is founded in India
- 2014**
New high capacity fine shredders are put into operation
- 2016**
SID installs the first hazardous waste SMP in China
- 2018**
Manufacturing buildings are tripled on SID Machinery (Beijing) Co., Ltd.
- 2021**
Beijing SID Environmental Technology Co., Ltd. is founded
- 2023**
SID Machinery (Changzhou) Co., Ltd. new factory is built

Pre-Shredders

SID
www.sidsa.ch

XLC 4500/8

oupe vaerthe

XLC 3000

XLC 4500

XLC 7300



// SIDSA's Pre-Shredders

Are widely known as the sturdiest and the most reliable machines in the market. They guarantee high throughput and very good productivity with low maintenance and operational costs.

Our primary shredders are suitable for a wide variety of products such as: industrial, bulky, municipal and hazardous waste.

MAIN APPLICATION FIELDS



- + Very powerful installations up to 630 kW
- + Wide range of throughput capacities for a variety of products
- + Waste can be shredded in each sense of rotation
- + Wear parts are easily and independently exchangeable
- + Process of waste reduction is completely automated using hydraulic adjustments and modern customized IT programs
- + All wear parts are completely reweldable
- + Frames of unlimited lifetime
- + Customisation of shredding shaft and tools according to customer requirements
- + Also available as: Monorotor (XLC 3000 MR and XLC 4500 MR) and Trirotor (XLC 4500 TR) versions
- + Wide range of options, including door for automatic ejection of unshreddable products, hydraulic displacement unit, closing flap, automatic lubrication unit, electric drive etc.



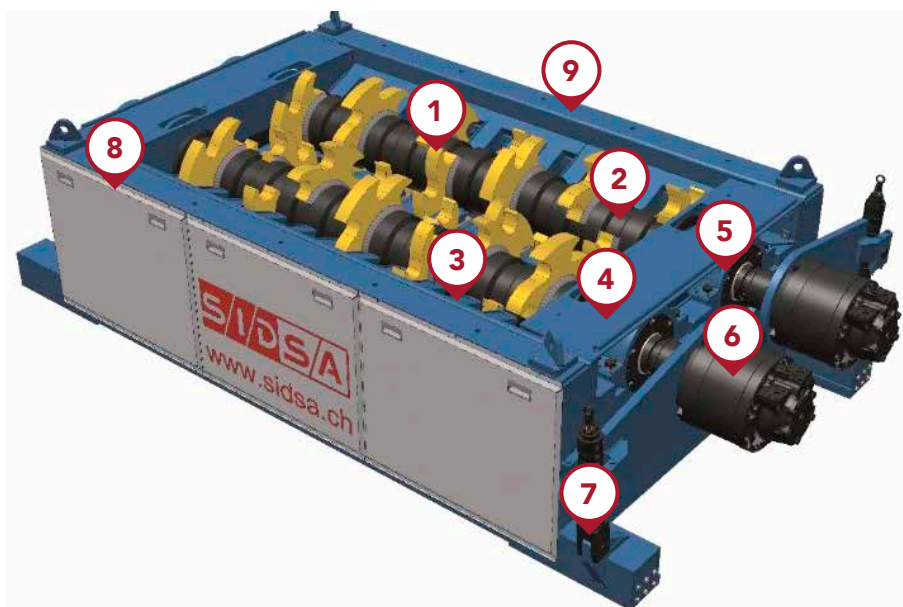

// XLC-Series Spotlight



1. Highly resistant hooks

High resistance to wear, several times reweldable, optimized shredding geometry

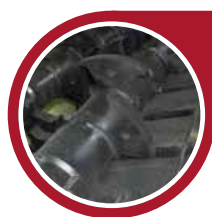

2. Shafts

Durable and multiple reweldable CrNiMo shafts without built-in obsolescence



3. Combs

Central and side combs are easily exchangeable, reweldable and adjustable for adopted granulometry



4. Housing in two parts

Easy and quick exchange of the whole shafts – thanks to the screwed connection of the frame



5. Patented sealing for bearings

Quadruple sealing preventing leakages, even for liquids



6. Drive

Especially designed hydraulic or electric drive for optimal torque and performance, runs perfectly in extreme conditions



7. Shock absorbers

Efficient protection of the driving system against overloads



8. Ejection door

Hydraulically driven door for automatic ejection of unshreddable products



9. Frame

Frame of unlimited lifetime

DIMENSIONS AND TECHNICAL SPECIFICATIONS

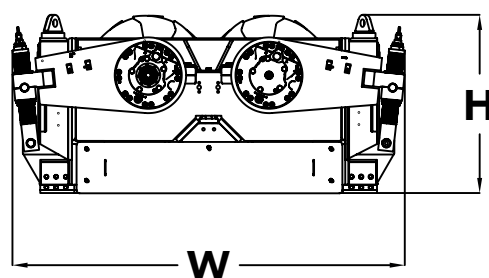
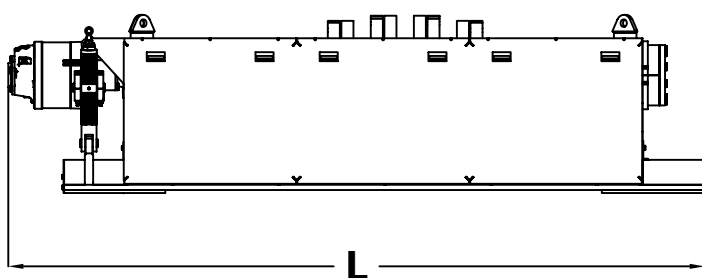

TR version

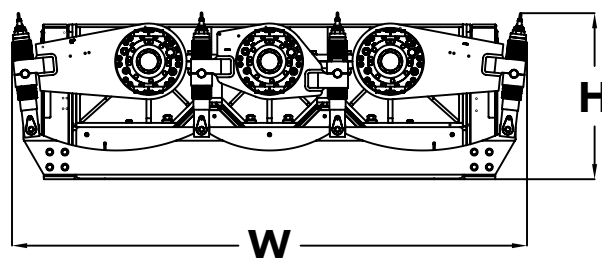
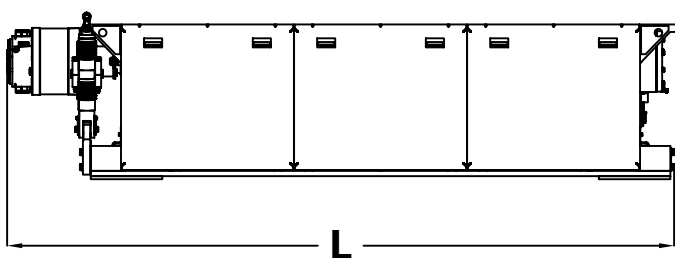

	XLC 3000	XLC 4500	XLC 4500 TR	XLC 7300
Dimensions L x W x H (m x m x m)	3.3 x 2.1 x 1.0	4.8 x 2.7 x 1.2	4.8 x 3.4 x 1.2	4.8 x 3.3 x 1.7
Cutting chamber (m x m)	1.8 x 1.6	2.6 x 1.8	2.6 x 2.6	2.7 x 2.7
Weight (t)	10	21	27	38
Installed power (kW)	160 – 250	200 – 500	400 – 750	315 – 945
Throughput (up to t/h)				
Bulky waste	25	60	95	120
Domestic waste and MSW	60	150	230	280
Wood and easily breakable products	25	60	95	120



Fine Shredders

SRF 1800

SRF 2200

SRF 2800



// SIDSA's Fine Shredders

Consist of one or two shafts each driven by an electric motor with high torque. The transmissions are provided by separate V-belt gearboxes.

Our fine shredders are suitable for a wide variety of installations such as: cement, sorting, recycling and household waste treatment facilities and RDF installations.

MAIN APPLICATION FIELDS

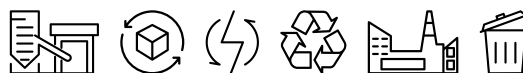

- + Sturdy alloy steel rotor
- + Design customized to requested granulometry
- + Quick replacement of knives
- + Hydraulic access door
- + Load start-up
- + Automatic reverse overload
- + Optionally with hydraulic drive



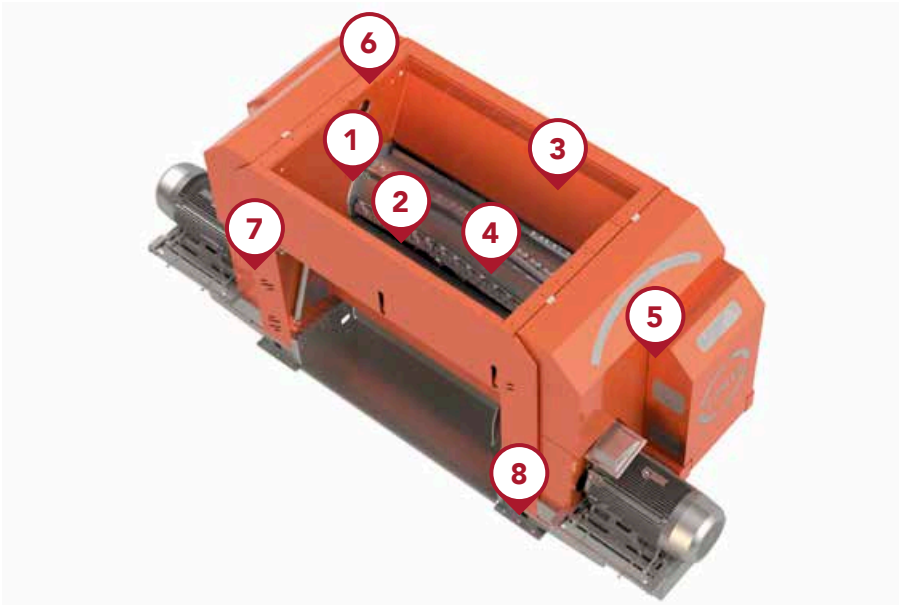

// SRF-Series Spotlight



1. Improved Bearings

Wider design and higher dynamic load for longer lifetime under comparable working conditions



2. Wear-resistant materials

Wear-resistant plates are used in product-contacting areas to increase lifetime under wear



3. Machine body

The same frame can handle all types and sizes of rotors and cutters and all types of drives to adapt the capacity, shredding size as well as the waste to be treated



4. Rotor diameter

Higher linear cutting speed of knife tip for better cutting effect and greater moment of inertia



5. Number and type of belts

High service factor for stronger power transmission to reduce the risk of slippage in extreme conditions and extends belt lifetime



6. Material level sensor in hopper

Real-time level detection (horizontal and vertical) for more flexibility, optimized feeding and increased production capacity



7. Transport dimensions
Footprint of even the largest fine shredder in SID portfolio can fit in a standard 40' OT container



8. Robust body structure
Design of mechanical structure as closed profile for higher internal loads and reduced vibrations

DIMENSIONS AND TECHNICAL SPECIFICATIONS

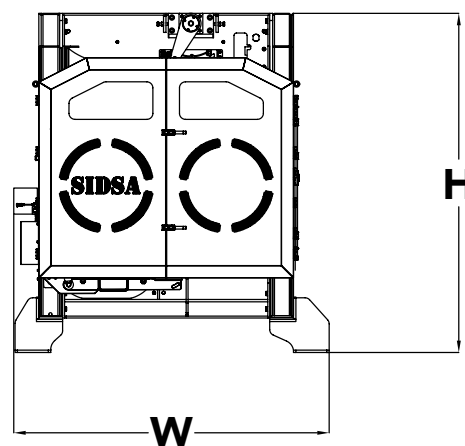
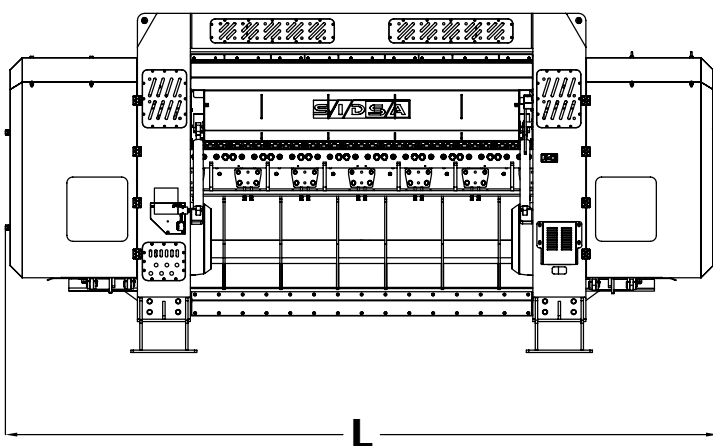

	SRF 1800	SRF 2200	SRF 2800
Dimensions L x W x H (m x m x m)	5.6 x 2.9 x 2.9	6.2 x 2.9 x 2.9	6.9 x 2.9 x 2.9
Cutting chamber (m x m)	1.8 x 1.9	2.1 x 1.9	2.8 x 1.9
Weight (t)	22	26	30
Installed power (kW)	2 x 110 – 2 x 160	2 x 132 – 2 x 200	2 x 160 – 2 x 250
Product granulometry (mm)	10 – 160	10 – 160	10 – 160
Throughput (up to t/h)			
Bulky waste	8	12	20
Industrial, special and hazardous waste	10	15	25
Domestic waste and MSW	15	24	40
Wood and easily breakable products	8	12	20
Operation speed (rpm)	60 – 350	60 – 350	60 – 350



Rotary Shears

2-Shafts

S 100

S 350

S 200

S 400

S 300

S 500

// SIDSA's 2-Shaft Rotary Shears



Show one of the highest shredding throughputs and the lowest energy consumptions. This design makes operational and maintenance costs very attractive.

These reliable and long lifetime machines are suitable for a wide range of applications, including: MSW, industrial, food, hazardous and medical waste and tire treatment.

MAIN APPLICATION FIELDS



- + Design customized to requested granulometry
- + Special designed cutters for optimal shredding
- + Hydraulic door for the automatic ejection of unshreddable parts
- + Quick exchange of all wear and spare parts
- + Quadruple sealing preventing leakages even for liquids
- + Mobile versions are available



Our customized 2-shaft shredders exist with the following options:



Ram feeder

For pushing the product onto the cutting tools



Ejection door

For easy removal of unshreddable parts



High torque electric drive

As an alternative to the hydraulic drive type



Offset shaft arrangement

e.g. for chemical waste



// S-Series Spotlight



1. CrNiMo cutter rings

Entirely machined, multiple heat treated
Option: segmented cutting rings



2. Combs

Easily exchangeable combs



3. Housing in two parts

Easy and quick exchange of the whole shafts – thanks to the screwed construction of the frame

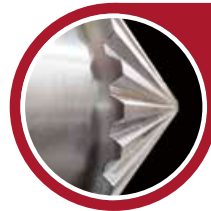

4. Ribbed shafts

The solid shafts have special ribbing design which provides optimal torque transmission



5. Shock absorbers

Efficient protection of the driving system against overloads



6. Drive

Especially designed hydraulic or electric drive for optimal torque and performance, runs perfectly in extreme conditions



7. Patented sealing for bearings

Quadruple sealing preventing leakages, even for liquids



8. Ejection door

Hydraulically driven door for automatic ejection of unshreddable products

DIMENSIONS AND TECHNICAL SPECIFICATIONS

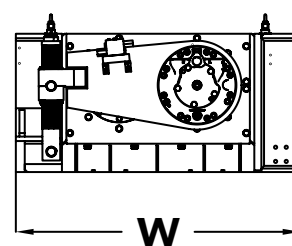
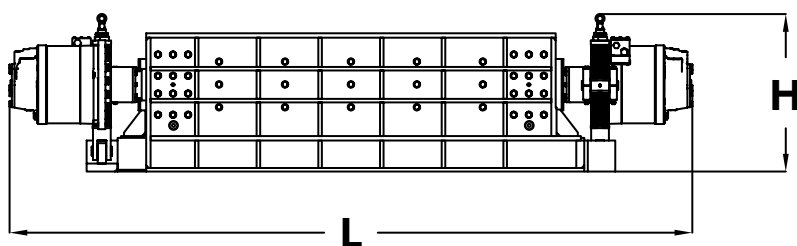

	S 100	S 200	S 300	S 350	S 400	S 500
Dimensions L x W x H (m x m x m)	2.7 x 1.1 x 0.5	3.5 x 1.8 x 0.7	4.0 x 1.8 x 1.1	4.5 x 1.8 x 1.1	5.2 x 2.2 x 1.1	5.9 x 2.6 x 1.7
Cutting chamber (m x m)	1.1 x 0.7	1.3 x 0.9	1.6 x 1.1	2.0 x 1.1	2.1 x 1.6	2.7 x 1.6
Weight (t)	4	7	12	14	27	35
Installed power (kW)	18.5 – 55	37 – 200	90 – 400	110 – 400	250 – 630	264 – 630
Throughput (up to t/h)						
Bulky waste	–	–	20	20	40	60
Industrial, special and hazardous waste	4	8	25	30	50	80
Domestic waste and MSW	8	16	40	50	80	120
Wood and easily breakable products	–	5	20	25	50	70
Throughput (up to pcs/h)						
Car tyres	500	1000	2000	2500	4000	5000
Lorry tyres	–	40	300	360	500	600
drums – 16 kg	100	200	400	400	800	1000
drums – 20 kg	30	60	400	400	800	1000



Rotary Shears

4-Shafts

S 200 4S

S 300 4S

S 350 4S



// SIDSA's 4-Shaft Rotary Shears

Are one of SIDSA's key technological innovations for fine shredding.

With the LAS system and shaft's mutual position they are suitable for shredding a wide range of products, for example tires, RDF installations, industrial and hazardous waste as well as mixed waste.

MAIN APPLICATION FIELDS



- + Lowering and Sliding (LAS) system for easy and quick screen replacement
- + Regular output size of products after screen
- + Multiple drive system for optimal power transmission
- + 4 shafts and 4 drives ensure high flexibility for challenging products

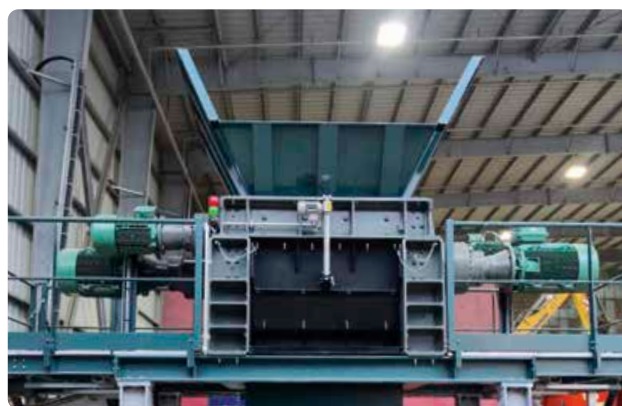

DIMENSIONS AND TECHNICAL SPECIFICATIONS

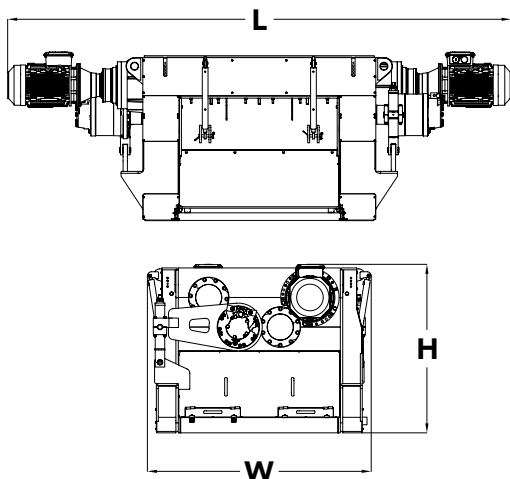

	S 200 4S	S 300 4S	S 350 4S
Dimensions L x W x H (m x m x m)	4.2 x 2.0 x 1.4	4.4 x 2.2 x 1.7	4.8 x 2.2 x 1.7
Cutting chamber (m x m)	1.3 x 1.3	1.8 x 1.6	2.0 x 1.8
Weight (t)	12	18	22
Installed power (kW)	90 – 200	180 – 500	180 – 500
Throughput (up to t/h)	10	30	40

A large industrial facility with multiple levels of steel structures, walkways, and machinery. A prominent orange machine is visible on a middle level, and a worker in safety gear is standing nearby. The scene is brightly lit, suggesting an outdoor or well-lit indoor environment.

SMP-Installations

Shredding. Mixing. Pumping.

Flowchart

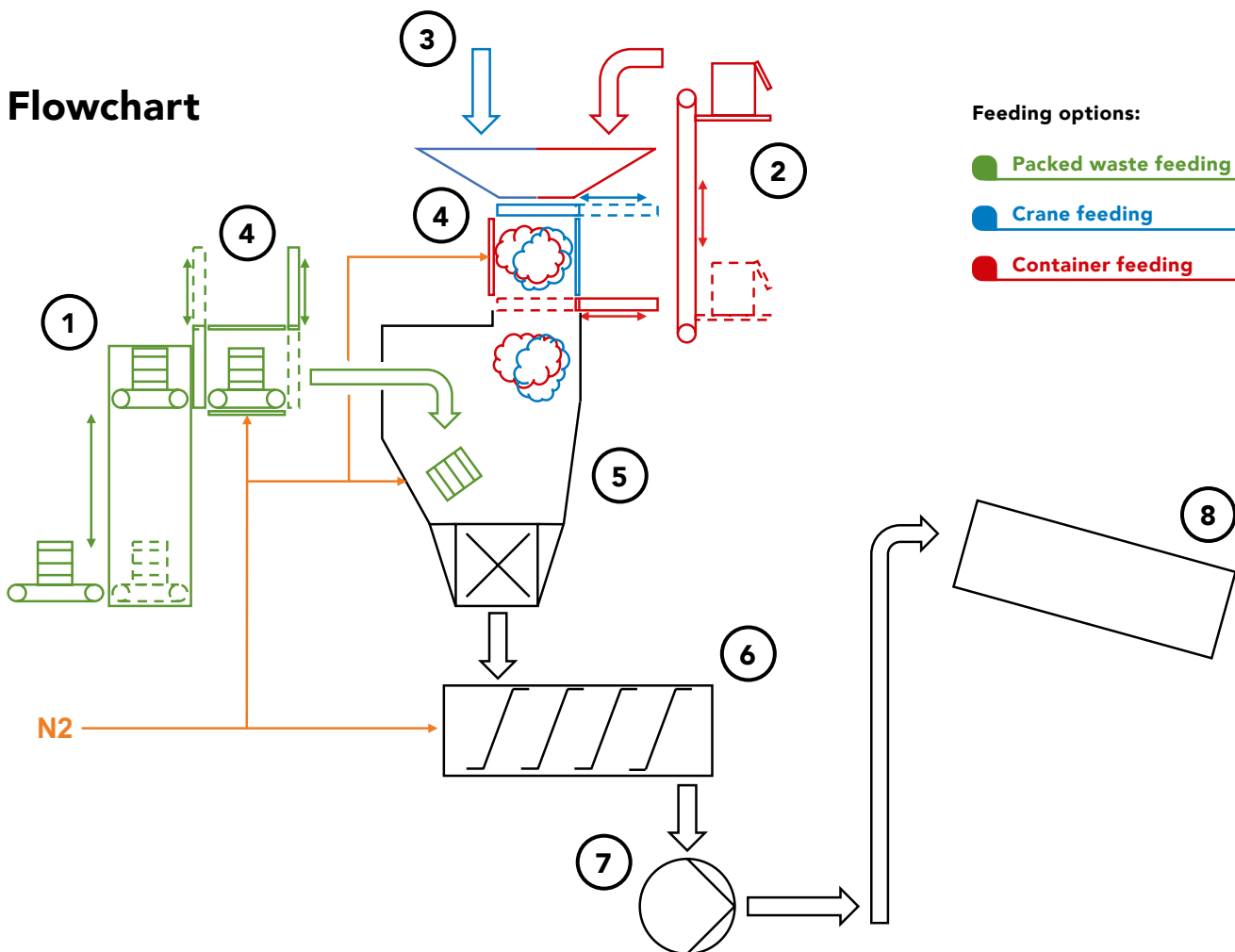

LEGEND

- | | |
|--|--|
| <p>① Packed waste feeding via conveyor systems and vertical conveyor</p> <p>② Container feeding into feed hopper by tipping via vertical conveyor</p> <p>③ Feeding of bulky waste into feed hopper using a crane/grabber</p> <p>④ Interlocking chamber for crane and container feeding with N₂-blanketing</p> | <p>⑤ Size reduction by shredder (cf. to section „Rotary shears“) incl. feed hopper with N₂-blanketing and overpressure protection</p> <p>⑥ Mixer for homogenizing the shredded waste (see chapter „Mixers“)</p> <p>⑦ High-density pump for conveying the homogenized product via high-pressure pipes to the end consumer of the system (see chapter „Pumps“ and “general options” – Gate valves, Lances)</p> <p>⑧ Rotary kiln as end consumer of the SMP-system</p> |
|--|--|

**SHREDDING****MIXING****PUMPING****// 1ST STEP: SHREDDER**

Depending on the client's needs, we design and build the most suitable shredder.

// 2ND STEP: MIXER

After shredding, waste is mixed to a homogeneous product.

// 3RD STEP: PUMP

Mixed product is pumped by the specially designed SIDA pump to the final use.

// INTERLOCKING CHAMBER

This device enables to seal the treatment process, which is especially relevant for hazardous waste.

// BLANKETING SYSTEM

Enables operation with reduced explosive risk.

// CONTROL OF ATMOSPHERE

SIDA is specialized in the field of design, development and construction of turnkey SMP and kiln feeding installations for hazardous and other types of waste.

SMP installations are particularly suitable for handling hazardous waste and are designed for maximum safety (e.g. to minimize the risk of contamination and/or explosions).

These systems comply with the highest safety standards and are equipped with oxygen control systems (monitoring and blanketing) in the areas of hazardous products.

The SMP system is designed for an optimized industrial use:

The processed waste can be used as an alternative fuel to reduce primary energy costs, e.g. in the cement industry. The physical and chemical homogeneity of the shredded and mixed waste makes it particularly attractive as a substitute fuel. The SMP technology is therefore a very attractive investment for SIDSA's national and international business clients and partners.

The system brings the following noticeable advantages depending on the sector:

- + Reduction of primary energy costs by the use of alternative fuels^①
- + Increased safety at work due to automated operation. The SMP can be operated by a single person^{①②}
- + Higher throughput (up to 20 %)^②
- + Higher lifetime of the key components (e.g. +20% for the cladding)^②
- + Reduction of additives in flue gas treatment system^②
- + Increase of installation availability due to reduced kiln maintenance operations^②

① Cement industry

② Hazardous waste incineration



Shredder



Mixer



Piston Pump



Pumps

SPP 15

STPP 15

SPP 25

STPP 25

SPP 35

STPP 35

MAIN APPLICATION FIELDS

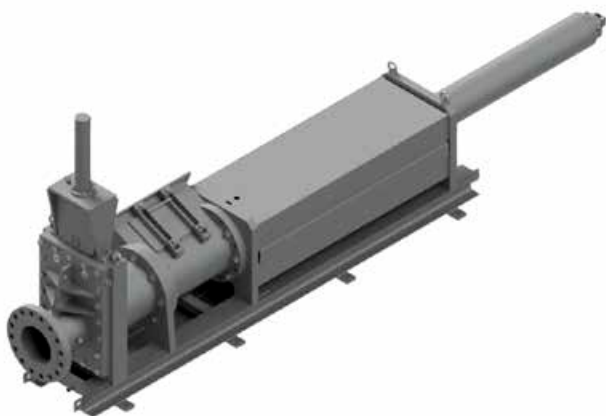

// SIDSA's SPP Pumps

For challenging applications i.e. high viscous liquids with foreign bodies.

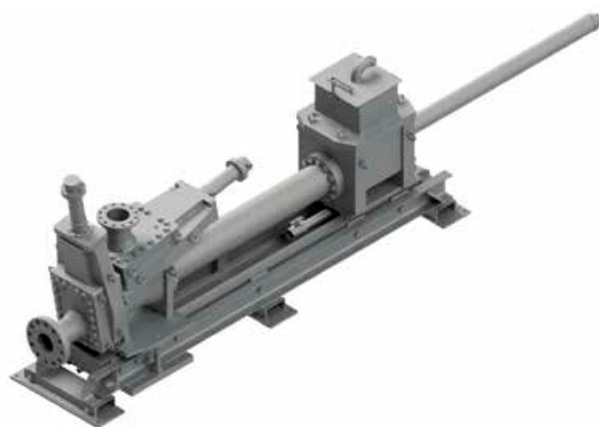

// SIDSA's STPP Pumps

For pumping pasty material. Also available as double tubular piston pump (DTPP) for continuous pumping.

- + SPP: Sturdy and easy dismantable cutting ring and piston head designed to pump and cut even long pieces
- + Adaptable pump pressure to enable long pumping distances
- + More than 30 years of experiences to develop turnkey solutions to the highest technological standards
- + Use of high sealing systems and highly abrasion resistant wear parts
- + Hydraulic cylinder is separated from the pump to avoid oil contamination and reducing maintenance
- + Continuous measuring and regulation to increase operational flexibility, allowing excellent integration in overall system
- + Top or side feeding of material with reduced risk of clogging and higher loading capacities. For SPP pump due to rotatable inlet (180°)
- + Guillotine in the outlet area prevents material from flowing back into the pump chamber

DIMENSIONS AND TECHNICAL SPECIFICATIONS

SPP

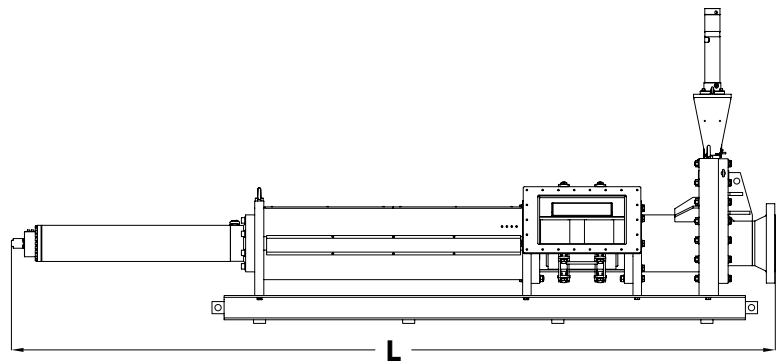
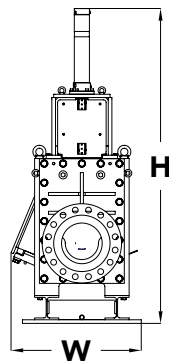

STPP

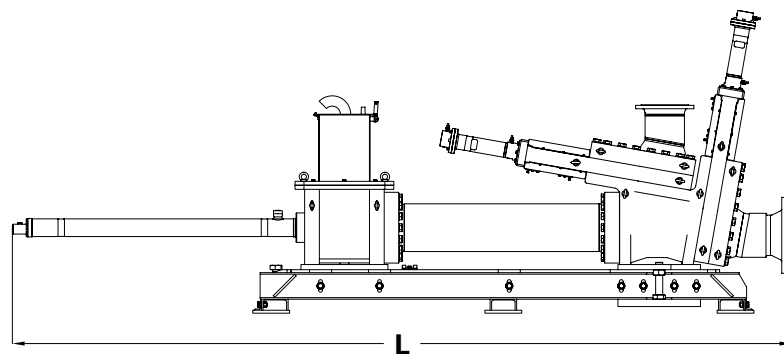
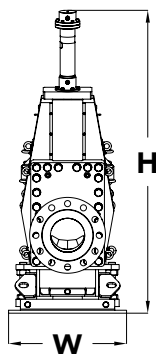

Pumps

	SPP 15	SPP 25	SPP 35	STPP 15	STPP 25	STPP 35
Dimensions L x W x H (m x m x m)	3.3 x 0.6 x 1.3	5.3 x 0.8 x 1.9	6.3 x 1.0 x 2.6	4.1 x 0.8 x 1.7	5.3 x 0.8 x 2.1	6.3 x 1.0 x 2.7
Weight (t)	1.2	3	7	4	5	8
Pressure (up to bar)	160	160	160	160	160	160
Diameter (mm)	150	250	350	150	250	350
Piston stroke (mm)	625	1150	1420	min. 1000	min. 1000	min. 1000
Throughput (up to m³/h)	4	8	15	12	20	100

Mixers

MIX6

MIX10

MIX10P

MIX12P

MAIN APPLICATION FIELDS



Mainly used in hazardous waste plants to homogenise the product but also suitable for other industrial applications.

// SIDSA's Mixers

Are continuous, hydraulic or electric-driven, dead-space free mixers with a horizontal shaft equipped with specific mixing tools enabling maximal back-mixing and cross flow.

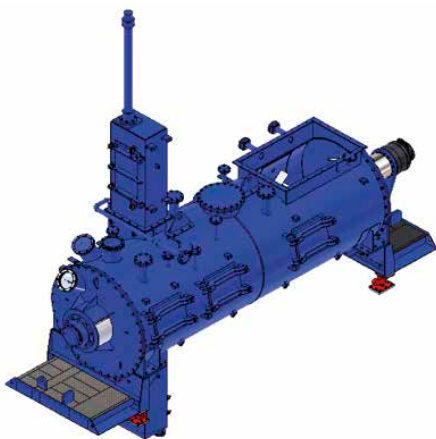

Weir: separate installation (MIX...)

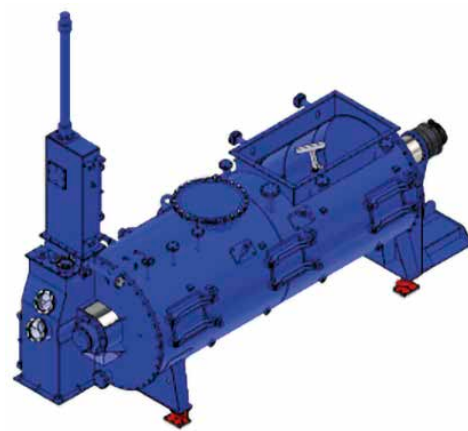

Weir: integrated in outlet (MIX...P)

The movable weir allows a constant mixing result and the flow rate can be regulated.

- + Single-piece solid shaft of forged high strength CrMo alloyed steel to optimize lifetime
- + Mixer chamber covered with replaceable wear plates
- + Screwed mixing elements made of wear-resistant hard metal alloy
- + Stuffing box packing with split rings for N₂-injection to maximise machine tightness

DIMENSIONS AND TECHNICAL SPECIFICATIONS

MIX...

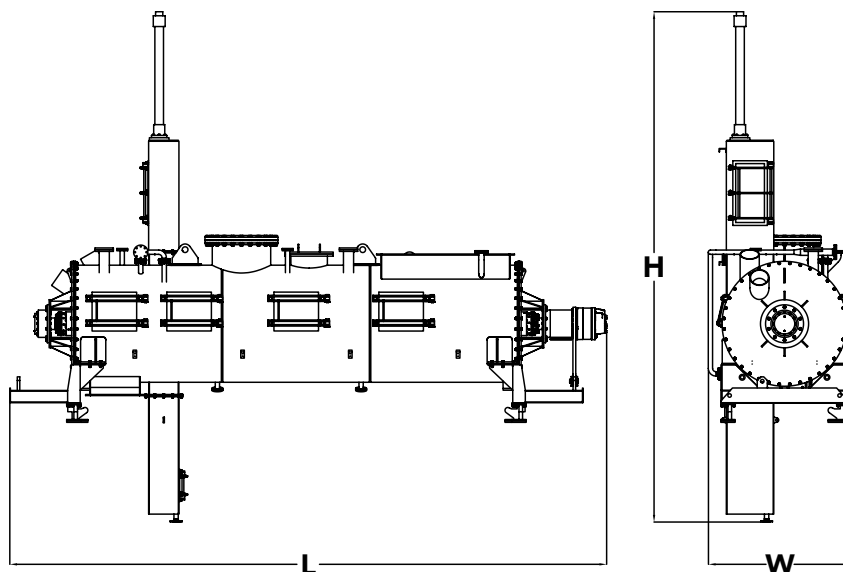

Mixers

MIX...P

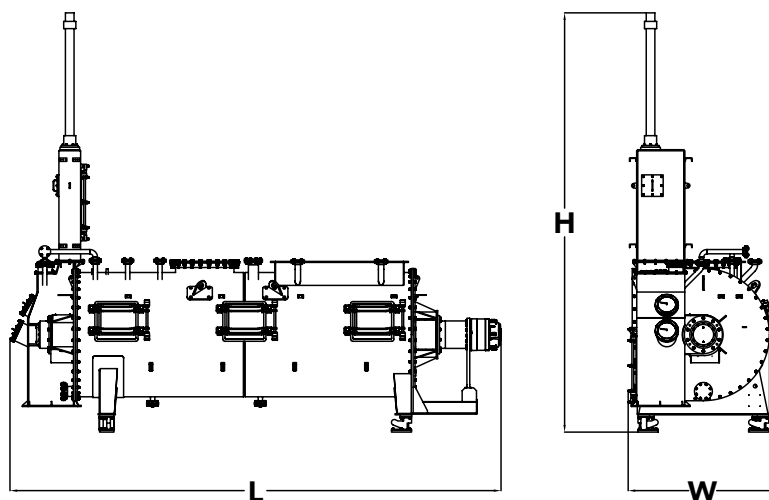

	MIX6	MIX10	MIX10P	MIX12P
Dimensions L x W x H (m x m x m)	6.8 x 2.3 x 7.2	8.3 x 2.3 x 7.2	6.9 x 2.1 x 5.6	8.4 x 2.1 x 5.6
Weight (t)	13.2	15.6	13.2	15.6
Total volume (m³)	6.6	9.5	9.6	12.6
Operation volume (m³)	2.5 – 4.5	4 – 6.6	4 – 7.0	5 – 9.0
Installed power (kW)	55 – 90	55 – 90	55 – 90	55 – 90
Throughput (up to m³/h)	5 – 13	10 – 20	10 – 20	12 – 24

General Options

For Single Equipment



Offset shaft arrangement
e.g. for chemical waste

Rotary Shears » 2 Shafts

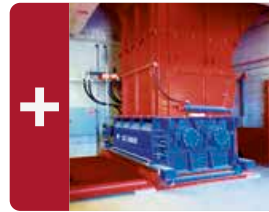

Hydraulic displacement system
for better maintenance accessibility,
on demand with integrated closing flap

**Pre-Shredders, Fine Shredders,
Rotary Shears**



Adjustable number of shafts
Mono- and Trirotor versions are available,
application-dependent

Pre-Shredders



Hydraulic and automatic ejection door
for easy removal of unshreddable parts

**Pre-Shredders, Fine Shredders,
Rotary Shears**



Ram feeder
for pushing the product onto the
cutting tools

Rotary Shears » 2 Shafts



High torque electric drive
as an alternative to the hydraulic drive
type

**Pre-Shredders, Fine Shredders,
Rotary Shears, Mixer**



Central greasing unit
automatic, periodic lubrication with
movement monitoring

**Pre-Shredders, Fine Shredders,
Rotary Shears, Mixer, Pumps**

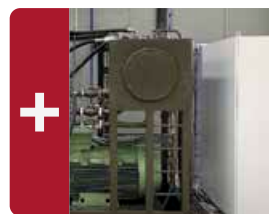

**Electric cubicle fixed
to hydraulic unit**
allows pre-wiring in the workshop to
reduce commissioning workload

**Pre-Shredders, Fine Shredders,
Rotary Shears, Mixer, Pumps**



Remote access device
SID specialists can access quickly and
reliably f.e. in an event of failure

**Pre-Shredders, Fine Shredders,
Rotary Shears, Mixer, Pumps**



Radio remote control
for improved on-site handling and
operation

**Pre-Shredders, Fine Shredders,
Rotary Shears**



Sound-proof housing of hydraulic unit
reduction of the sound pressure level

**Pre-Shredders, Fine Shredders,
Rotary Shears, Mixer, Pumps**



Container
for outside installations, weather pro-
tection of electric and hydraulic unit

**Pre-Shredders, Fine Shredders,
Rotary Shears, Mixer, Pumps**



Customization of process connections
connections and fittings according to
DIN/ANSI/JIS standard

**Pre-Shredders, Fine Shredders,
Rotary Shears, Mixer, Pumps**



Customization of surface protection
based on customer requirements and
ambient conditions at installation site

**Pre-Shredders, Fine Shredders,
Rotary Shears, Mixer, Pumps**

Other Equipment



Bunker gates



Lifts



(Screening) screws



Interlocking chambers



Gate valves for high density pipes



Screens



Steel structures



Conveyors



Hoppers



Pushers



Lances for high density pipes



Control systems



Product feeders

SID, in close cooperation with the most trustworthy suppliers, will provide you with the best quality products and services.

We will advise and accompany you on each step of conception and planning process of your installation which we will build according to your needs.

many others on request

A close-up photograph of a welder wearing a grey and black 3M Speedglas welding helmet and a grey protective jacket. The welder is wearing red leather gloves and is using a welding torch to work on a metal piece held in a yellow vise. Bright sparks are flying from the welding point. The background is a blurred workshop setting.

Customer Services



// SIDSA's after-sales department

is available 24/7. You can always rely on our services.

Thanks to our experience and well-developed know-how, we can guarantee the longest possible lifetime and the lowest operational costs.

The high quality of the after-sale services is one of our key commitments.

// Spare parts

Our large number of spare parts, wear parts and consumables, a solid network between our companies in Switzerland, Germany and China, as well as a close cooperation with the leading worldwide suppliers and local partners guarantees highest availability for your installation.

// On site and at SIDSA service centers

We offer all necessary services on site and in our workshops with our mechanic, hydraulic and electric experts, such as:

- hard welding / hard facing
- preventive maintenance
- advice and consulting
- machine refurbishments
- reparations
- components exchange
- software updates



// Contract

We provide 3 types of after-sales contracts:

- order on demand
- framework contract
- preventive maintenance contract

SIDSA-Group



ARE YOU INTERESTED IN THE LATEST TOPICS IN THE RECYCLING INDUSTRY, INNOVATIONS AND FURTHER DEVELOPMENTS IN THE FIELD OF SHREDDER, MIXER AND PUMP TECHNOLOGY AS WELL AS CURRENT PROJECTS OF THE SIDSA GROUP?

Visit us
online at

WEBSITE



LINKEDIN

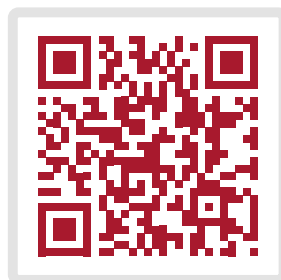

YOUTUBE

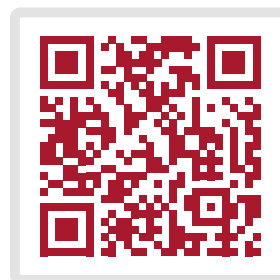

SID SA

Zone Industrielle
2123 Saint-Sulpice
Switzerland

Tel.: +41 32 862 65 00
Mail: info@sidsa.ch

SID Deutschland GmbH

Teinacher Straße 66
71634 Ludwigsburg
Germany

Tel.: +49 7141 94746-10
Mail: info@sidsa.de

SID Machinery (Beijing) Co., Ltd

Beiwu Dev. Zone, Shunyi District
101312 Beijing
China

Tel.: +86 10 6142 0016 ext. 8016
Mail: info@sidsa.cn

SIDSA Environmental Pvt. Ltd

Sr. No. 16/9, Pandurang Industrial Estate
Nanded City, Pune-411041
India

Tel.: +91 887 9585 277
Mail: info@sidsa.in



My Notes

SKETCHES & NOTES

